

# McKnight Crossings Church of Christ - Parking Lots Expansion Implementation

## Design Development Set

MCKNIGHT CROSSINGS CHURCH OF CHRIST  
2515 S. MCKNIGHT ROAD  
ST. LOUIS, MO 63124  
314-962-7026



7722 Big Bend Blvd.  
St. Louis, MO 63119  
t. 314.644.5700

PREPARED FOR -  
BID NUMBER -  
MSD # -  
ISSUE DATE -  
REVISED AND REISSUED -

### DRAWING INDEX:

COVER SHEET  
L-001 NOTES AND LEGENDS  
V-001 SITE SURVEY  
LD-100 DEMOLITION AND TREE PROTECTION PLAN  
L-100 OVERALL SITE PLAN  
L-110 ENLARGEMENT PLAN  
L-111 ENLARGEMENT PLAN  
L-140 SITE PLANTING PLAN  
L-500 DETAILS



VICINITY MAP:  
N.T.S.

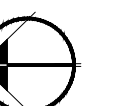



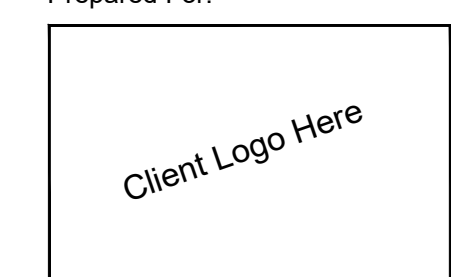

2515 S. McKnight Road  
St. Louis, MO 63124  
Project:  
McKnight Crossings  
Church of Christ



7722 Big Bend Blvd.  
St. Louis, MO 63119  
t. 314.644.5700

Consultant Role:  
Consultant Name  
Consultant Address Line 1  
Consultant Address Line 2  
XXX.XXX.XXX  
Consultant Role:  
Consultant Name  
Consultant Address Line 1  
Consultant Address Line 2  
XXX.XXX.XXX

Ted Spaid - Landscape Architect  
MO # LA - 162



SWT Design, Inc.  
Missouri State Certificate of  
Authority #2019038750

KEY PLAN

Issues	No.	Description	Date
	01	DD Submittal	06/05/20

Revisions	No.	Description	Date

SWT No. 20827.04  
MSD No. XXMSD-XXXXX  
Drawn KP, CB Reviewed KDR

Sheet Title  
SITE SURVEY

Number  
V-001

# LOTS 1, 3, 5 & 7 OF EAST PARKLANE, PB 55 PG 43, AND PART OF LOT 9 OF CHARLEVILLE FARM, PB 28 PG 84, IN U.S. SURVEY 1930, TOWNSHIP 45 NORTH, RANGE 6 EAST ST LOUIS COUNTY, MISSOURI

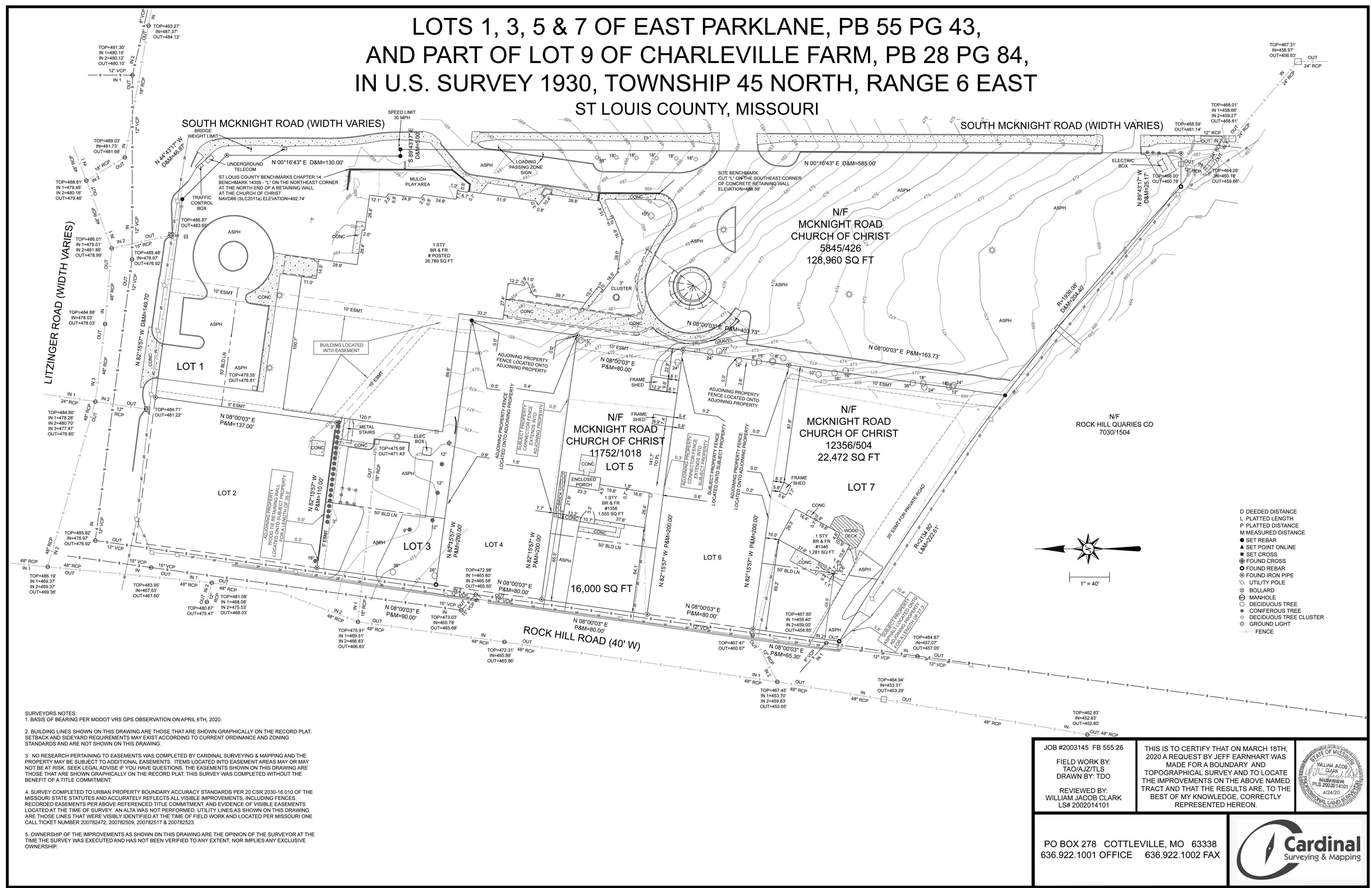

**SURVEYORS NOTES:**

1. BASIS OF BEARING PER MODOT VRS GPS OBSERVATION ON APRIL 6TH, 2020.
2. BUILDING LINES SHOWN ON THIS DRAWING ARE THOSE THAT ARE SHOWN GRAPHICALLY ON THE RECORD PLAT. SETBACK AND SIDEYARD REQUIREMENTS MAY EXIST ACCORDING TO CURRENT ORDINANCE AND ZONING STANDARDS AND ARE NOT SHOWN ON THIS DRAWING.
3. NO RESEARCH PERTAINING TO EASEMENTS WAS COMPLETED BY CARDINAL SURVEYING & MAPPING AND THE PROPERTY MAY BE SUBJECT TO ADDITIONAL EASEMENTS. ITEMS LOCATED INTO EASEMENT AREAS MAY OR MAY NOT BE AT RISK. SEEK LEGAL ADVICE IF YOU HAVE QUESTIONS. THE EASEMENTS SHOWN ON THIS DRAWING ARE THOSE THAT ARE SHOWN GRAPHICALLY ON THE RECORD PLAT. THIS SURVEY WAS COMPLETED WITHOUT THE BENEFIT OF A TITLE COMMITMENT.
4. SURVEY COMPLETED TO URBAN PROPERTY BOUNDARY ACCURACY STANDARDS PER 20 CSR 2030-16.010 OF THE MISSOURI STATE STATUTES AND ACCURATELY REFLECTS ALL VISIBLE IMPROVEMENTS, INCLUDING FENCES. RECORDED EASEMENTS PER ABOVE REFERENCED TITLE COMMITMENT, AND EVIDENCE OF VISIBLE EASEMENTS LOCATED AT THE TIME OF SURVEY. AN ALTA WAS NOT PERFORMED. UTILITY LINES AS SHOWN ON THIS DRAWING ARE THOSE LINES THAT WERE VISIBLY IDENTIFIED AT THE TIME OF FIELD WORK AND LOCATED PER MISSOURI ONE CALL TICKET NUMBER 200782472, 200782509, 200782517 & 200782523.
5. OWNERSHIP OF THE IMPROVEMENTS AS SHOWN ON THIS DRAWING ARE THE OPINION OF THE SURVEYOR AT THE TIME THE SURVEY WAS EXECUTED AND HAS NOT BEEN VERIFIED TO ANY EXTENT, NOR IMPLIES ANY EXCLUSIVE OWNERSHIP.

JOB #2003145 FB 555:26  
FIELD WORK BY:  
TAO/AJZ/TLS  
DRAWN BY: TDO  
REVIEWED BY:  
WILLIAM JACOB CLARK  
LS# 2002014101

THIS IS TO CERTIFY THAT ON MARCH 18TH, 2020 A REQUEST BY JEFF EARNHART WAS MADE FOR A BOUNDARY AND TOPOGRAPHICAL SURVEY AND TO LOCATE THE IMPROVEMENTS ON THE ABOVE NAMED TRACT AND THAT THE RESULTS ARE, TO THE BEST OF MY KNOWLEDGE, CORRECTLY REPRESENTED HEREON.



PO BOX 278 COTTLEVILLE, MO 63338  
636.922.1001 OFFICE 636.922.1002 FAX

**Cardinal**  
Surveying & Mapping

**A** SITE SURVEY  
SCALE: NTS

**LEGEND**

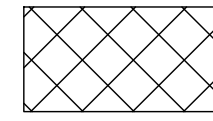

AREA TO BE REMOVED

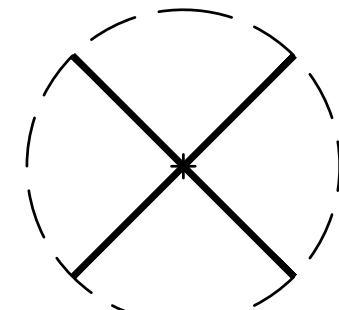

EXISTING TO BE REMOVED

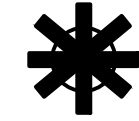

LIGHT FIXTURE TO BE REMOVED AND RELOCATED ON-SITE.

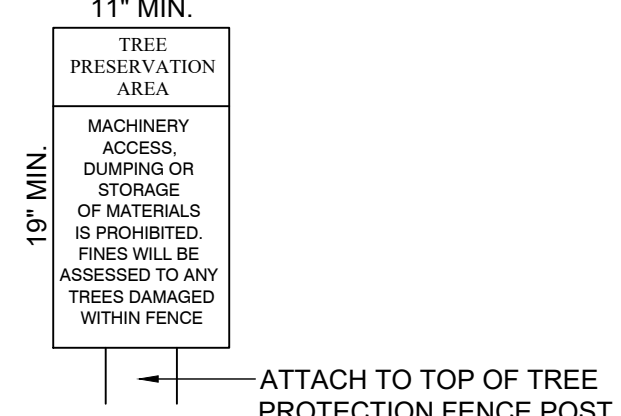

- NOTES:
1. TYPE SIZE SHOULD BE NO SMALLER THAN 48 PT. (1/2" HT.)
  2. SIMILAR SIGNS REQUESTING SUBCONTRACTOR COOPERATION AND COMPLIANCE WITH TREE PROTECTION STANDARDS ARE RECOMMENDED AT THE SITE ENTRANCE
  3. SIGNS SHOULD BE PLACED AT A DISTANCE NOT TO EXCEED 50'

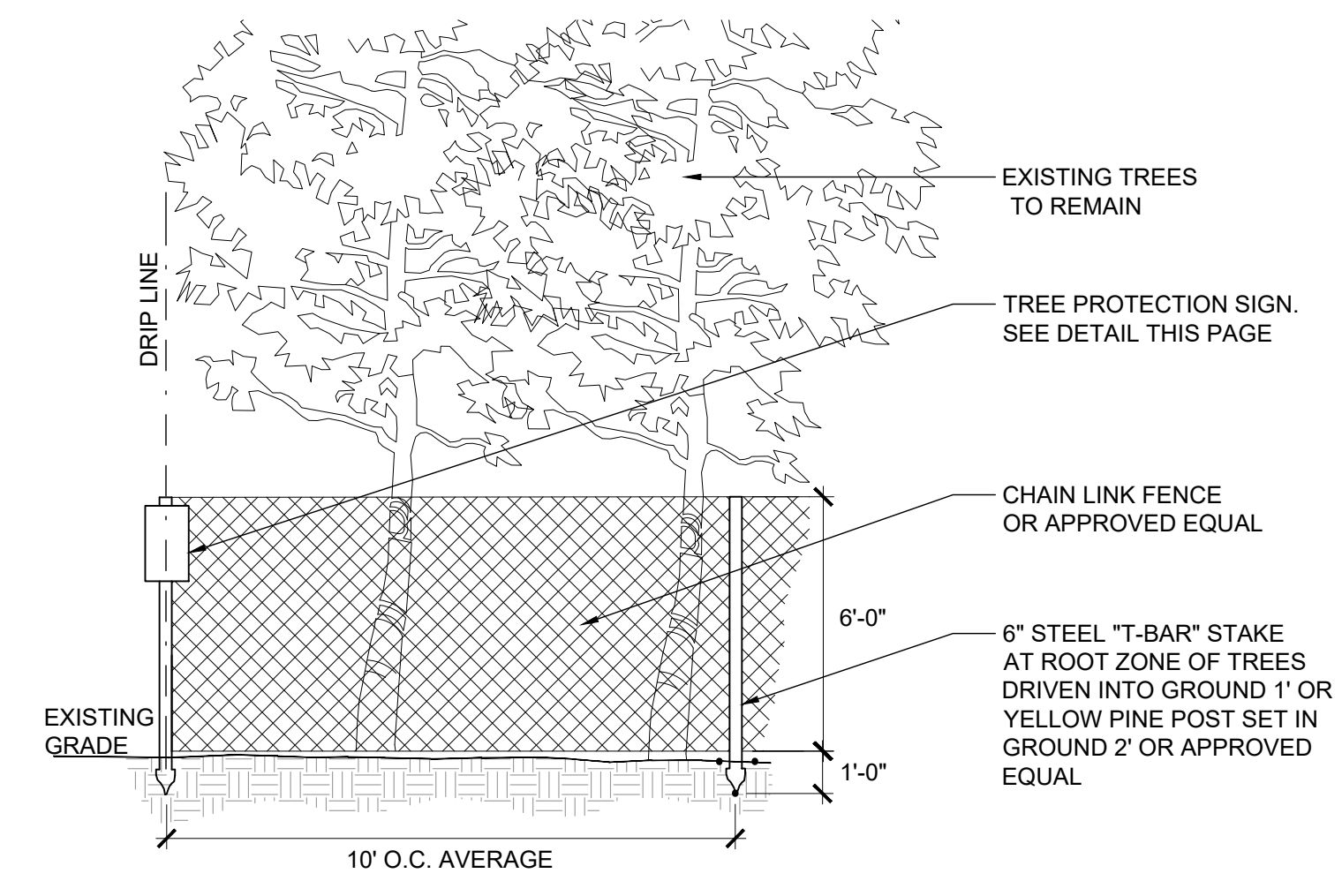

**A TYPICAL TREE PROTECTION**  
SCALE: 1"=4'

**B TREE PROTECTION SIGN**

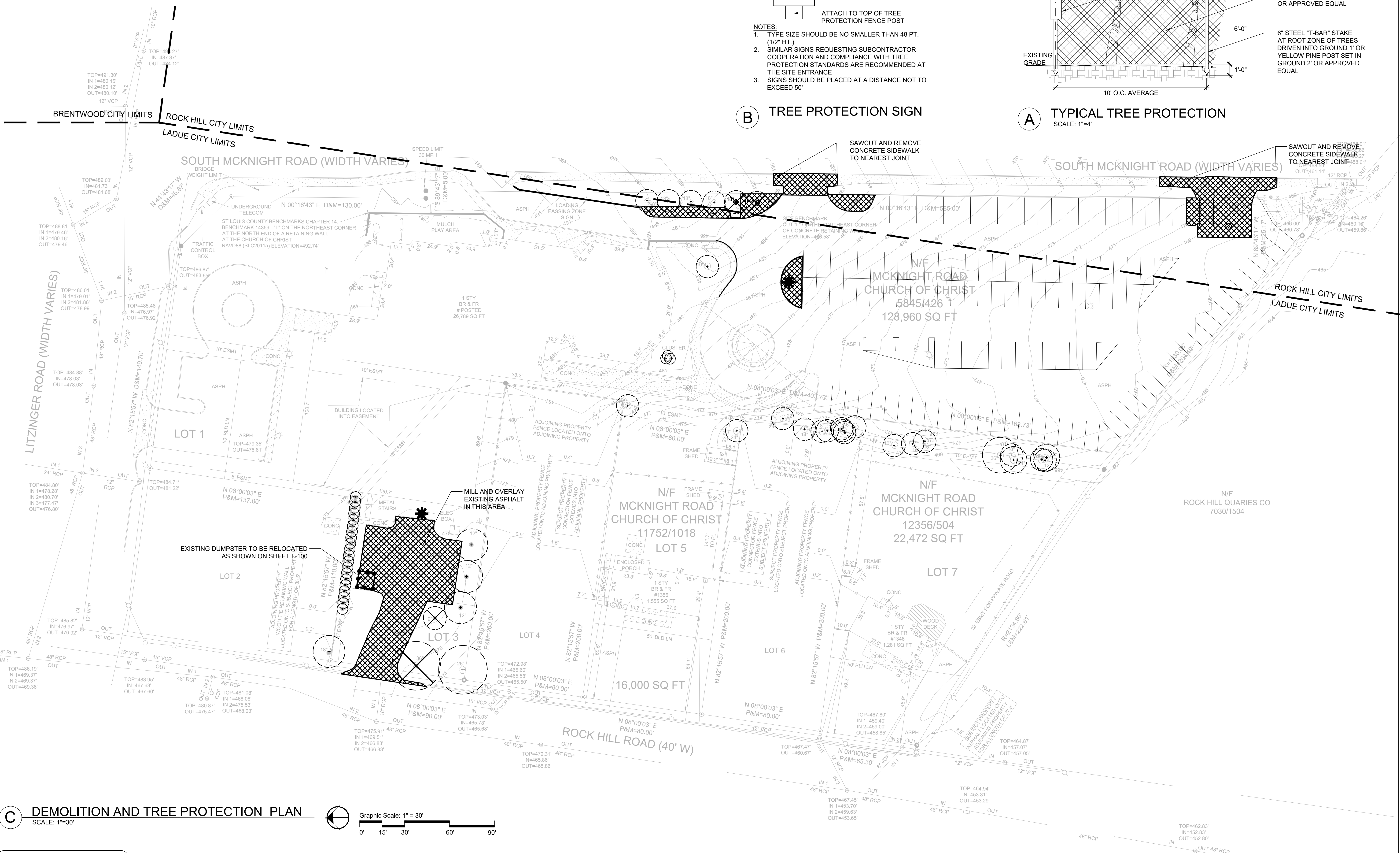

**C DEMOLITION AND TREE PROTECTION PLAN**  
SCALE: 1"=30'

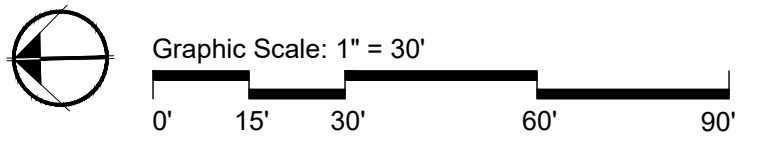

Call Before You DIG  
TOLL FREE  
1-800-344-7483  
MISSOURI ONE-CALL SYSTEM INC.  
MODOT (314) 340-4100

Prepared For:  
**Client Logo Here**  
2515 S. McKnight Road  
St. Louis, MO 63124  
Project:  
**McKnight Crossings  
Church of Christ**  
Landscape Architect:  
**SWT DESIGN**  
7722 Big Bend Blvd.  
St. Louis, MO 63119  
t. 314.644.5700

Consultant Role:  
Consultant Name  
Consultant Address Line 1  
Consultant Address Line 2  
XXX.XXX.XXXX  
Consultant Role:  
Consultant Name  
Consultant Address Line 1  
Consultant Address Line 2  
XXX.XXX.XXXX

Ted Spaid - Landscape Architect  
MO # LA - 162



SWT Design, Inc.  
Missouri State Certificate of  
Authority #2019038750

**KEY PLAN**

Issues

No.	Description	Date
01	DD Submittal	06/05/20

Revisions

No.	Description	Date
-----	-------------	------

SWT No. 20827.04  
MSD No. XXMSD-XXXXX  
Drawn KP, CB  
Reviewed KDR

Sheet Title  
**DEMOLITION AND TREE  
PROTECTION PLAN**

Number  
**LD-100**

NOTIFY LANDSCAPE ARCHITECT IMMEDIATELY IN EVENTS OF DISCREPANCIES, OMISSIONS, AND/OR CONFLICTS IN THE DRAWINGS OR SPECIFICATIONS. THE CONTRACTOR IS NOT AUTHORIZED TO SCALE THE DRAWINGS. ALL QUESTIONS IN REFERENCE TO CONTRACT DOCUMENTS SHALL BE IMMEDIATELY DIRECTED TO THE LANDSCAPE ARCHITECT.

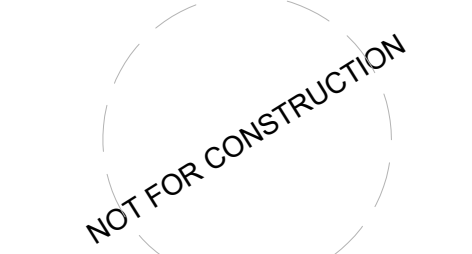
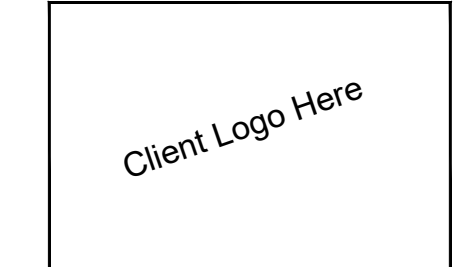

Issues

No.	Description	Date
01	DD Submittal	06/09/20

Revisions

No.	Description	Date
-----	-------------	------

June 5, 2020 - CURRENT PHASE OF PROJECT

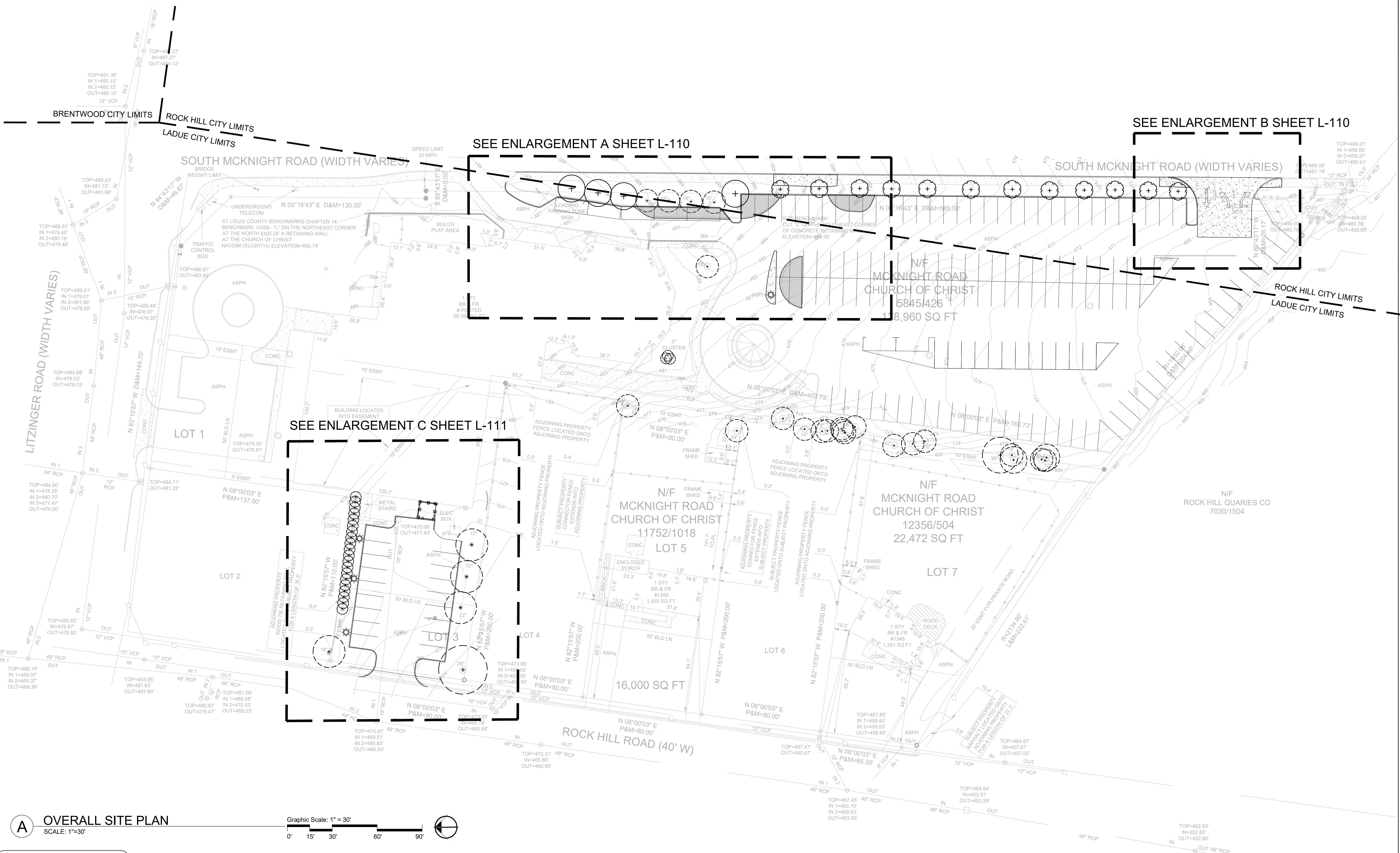

**A** OVERALL SITE PLAN  
SCALE: 1"=30'

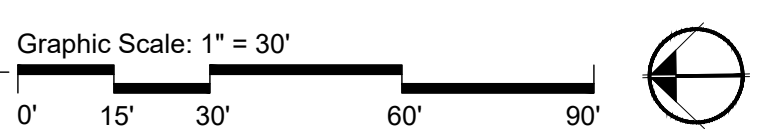

Call Before you DIG  
TOLL FREE  
1-800-344-7483  
MISSOURI ONE-CALL SYSTEM INC.  
MODOT (314) 340-4100

NOTIFY LANDSCAPE ARCHITECT IMMEDIATELY IN EVENTS OF DISCREPANCIES, OMISSIONS, AND/OR CONFLICTS IN THE DRAWINGS OR SPECIFICATIONS. THE CONTRACTOR IS NOT AUTHORIZED TO SCALE THE DRAWINGS. ALL QUESTIONS IN REFERENCE TO CONTRACT DOCUMENTS SHALL BE IMMEDIATELY DIRECTED TO THE LANDSCAPE ARCHITECT.



Issuances		
No.	Description	Date
01	DD Submittal	06/05/20

Revisions		
No.	Description	Date

**LEGEND**

- 1 STANDARD CONCRETE PAVING**  
4" THICK CONCRETE PAVING, BROOM FINISH. EDGES TO BE 1/4" TOOLED RADIUS. SEE CIVIL DRAWINGS FOR LAYOUT. CONTRACTOR TO COORDINATE LOCATION OF ALL JOINTS WITH LANDSCAPE ARCHITECT. SEE DETAIL X/X-X.
- 2 ASPHALT PAVING**  
FULL DEPTH ASPHALT PAVING FOR VEHICULAR TRAFFIC. SEE DETAIL C/L-500
- 3 ROLLED ASPHALT CURB**  
ROLLED ASPHALT PARKING LOT CURB TO MATCH EXISTING WHERE SHOWN. SEE DETAIL X/LX-X.X
- 4 PARKING LOT LIGHT FIXTURE**  
LIGHT FIXTURE TO MATCH EXISTING FIXTURE STYLE, COLOR, HEIGHT, AND LIGHT OUTPUT. FOOTING TO BE INSTALLED PER MANUFACTURER'S RECOMMENDATIONS.
- 5 CONCRETE CURB**  
CONCRETE CURB TO MATCH HEIGHT, COLOR AND WIDTH OF EXISTING CONCRETE CURBS. NEW CURBS TO TIE-IN TO EXISTING AS SHOWN.
- 6 CONCRETE DRIVE APRON**  
6" DEPTH CONCRETE APRON FOR ROADWAY TRANSITION TO PARKING LOT. SEE DETAIL X/X-X

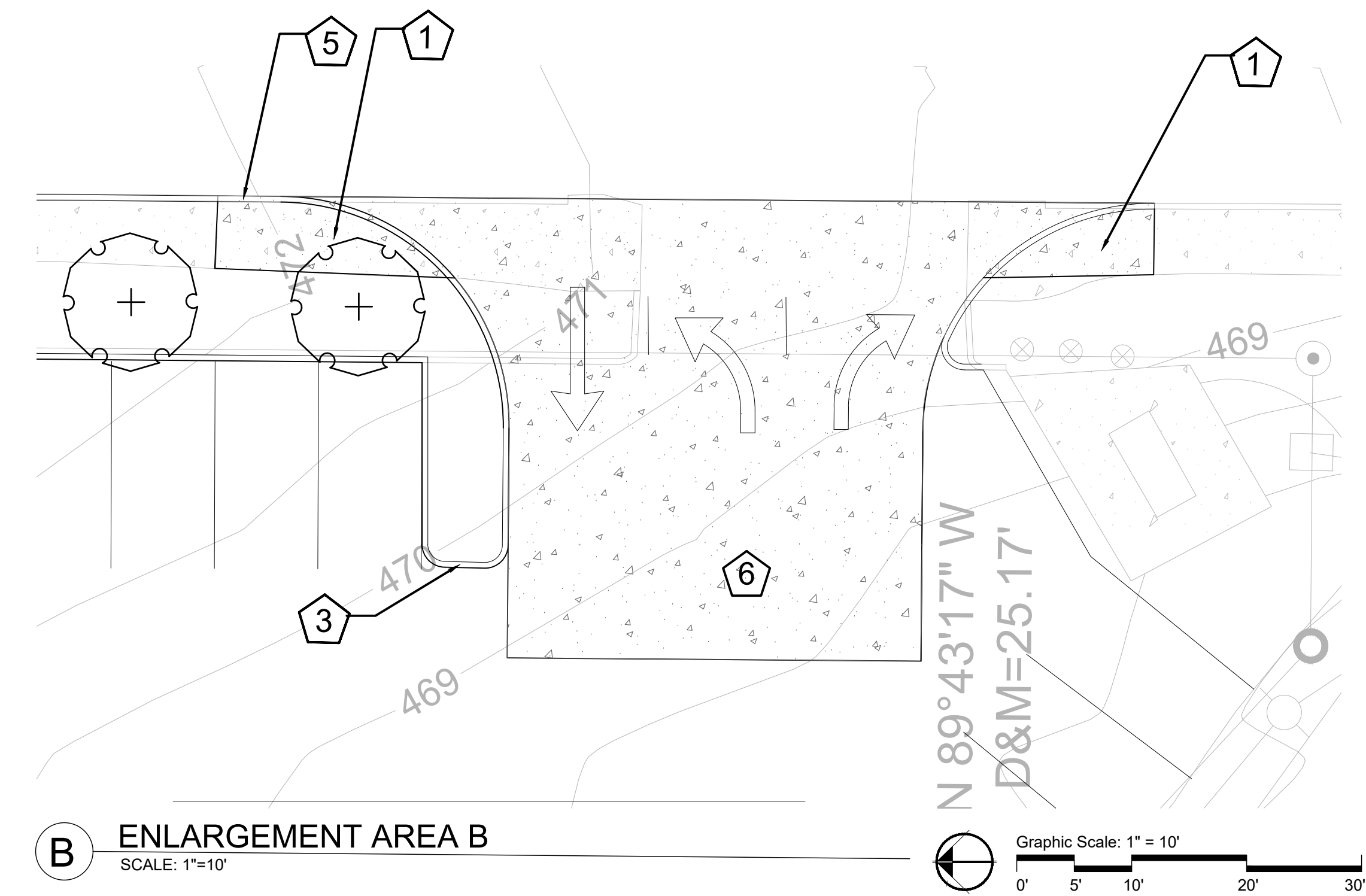

**B ENLARGEMENT AREA B**  
SCALE: 1"=10'

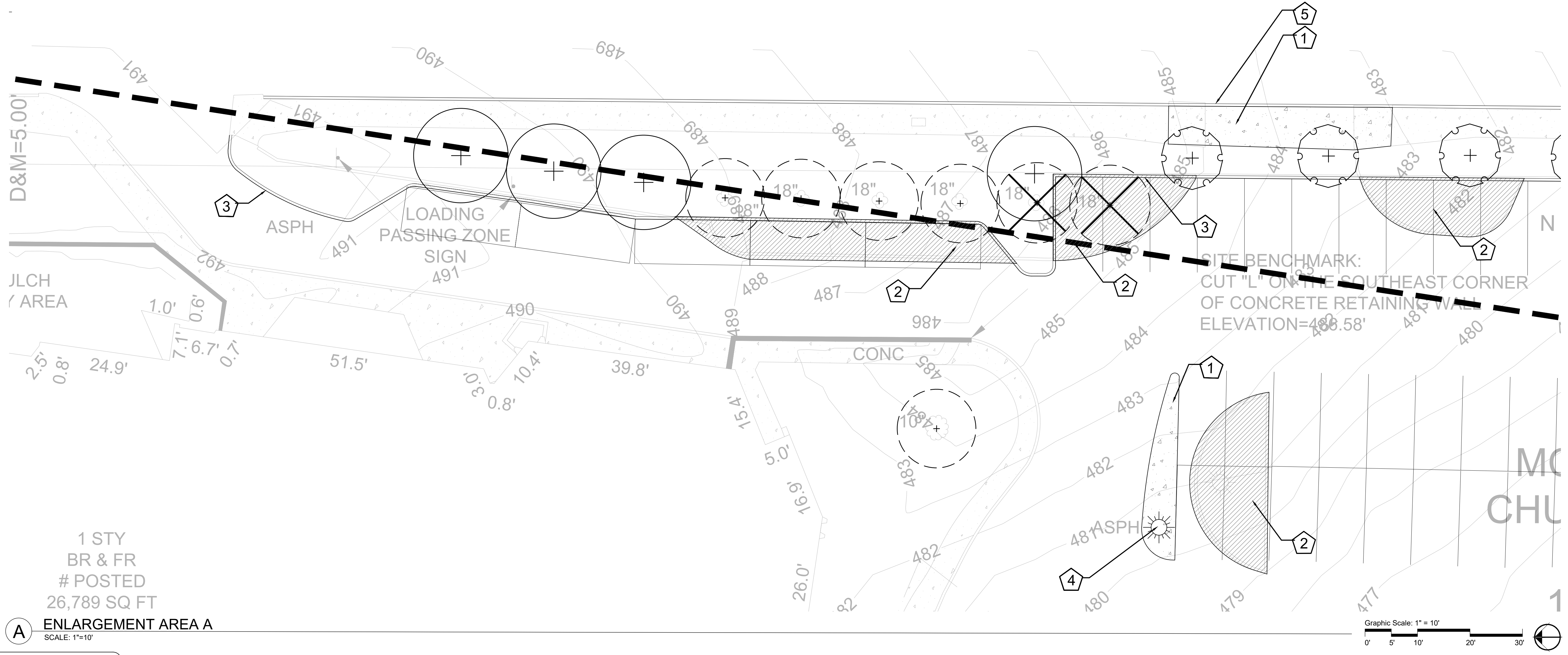
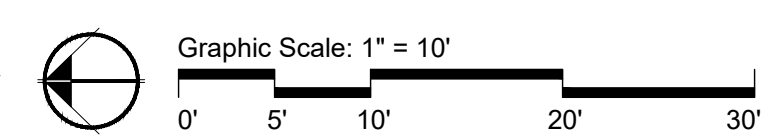

**A ENLARGEMENT AREA A**  
SCALE: 1"=10'

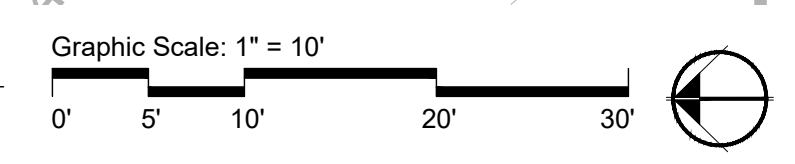

NOTIFY LANDSCAPE ARCHITECT IMMEDIATELY IN EVENTS OF DISCREPANCIES, OMISSIONS, AND/OR CONFLICTS IN THE DRAWINGS OR SPECIFICATIONS. THE CONTRACTOR IS NOT AUTHORIZED TO SCALE THE DRAWINGS. ALL QUESTIONS IN REFERENCE TO CONTRACT DOCUMENTS SHALL BE IMMEDIATELY DIRECTED TO THE LANDSCAPE ARCHITECT.

Call Before you DIG  
TOLL FREE  
1-800-344-7483  
MISSOURI ONE-CALL SYSTEM INC.  
MODOT (314) 340-4100

THIS DOCUMENT IS THE PROPERTY OF SWTD. IT IS TO BE USED ONLY FOR THE PROJECT AND SITE SPECIFICALLY IDENTIFIED HEREIN. IT IS NOT TO BE REPRODUCED, COPIED, OR TRANSMITTED IN ANY FORM OR BY ANY MEANS, ELECTRONIC OR MECHANICAL, INCLUDING PHOTOCOPYING, RECORDING, OR BY ANY INFORMATION STORAGE AND RETRIEVAL SYSTEM, WITHOUT THE WRITTEN PERMISSION OF SWTD. SWTD ASSUMES NO LIABILITY FOR ANY ERRORS OR OMISSIONS IN THIS DOCUMENT. SWTD IS NOT RESPONSIBLE FOR ANY CONSTRUCTION DEFECTS OR DAMAGES RESULTING FROM THE USE OF THIS DOCUMENT. SWTD IS NOT A LICENSED PROFESSIONAL ENGINEER OR ARCHITECT IN THE STATE OF MISSOURI. SWTD IS NOT A LICENSED PROFESSIONAL ENGINEER OR ARCHITECT IN THE STATE OF ILLINOIS. SWTD IS NOT A LICENSED PROFESSIONAL ENGINEER OR ARCHITECT IN THE STATE OF KANSAS. SWTD IS NOT A LICENSED PROFESSIONAL ENGINEER OR ARCHITECT IN THE STATE OF MISSOURI. SWTD IS NOT A LICENSED PROFESSIONAL ENGINEER OR ARCHITECT IN THE STATE OF MISSOURI.



2515 S. McKnight Road  
St. Louis, MO 63124

Project:  
**McKnight Crossings  
Church of Christ**

Landscape Architect:



7722 Big Bend Blvd.  
St. Louis, MO 63119  
t. 314.644.5700

Consultant Role:  
Consultant Name  
Consultant Address Line 1  
Consultant Address Line 1  
XXX.XXX.XXX

Consultant Role:  
Consultant Name  
Consultant Address Line 1  
Consultant Address Line 1  
XXX.XXX.XXX

Ted Spaid - Landscape Architect  
MO # LA - 162



SWT Design, Inc.  
Missouri State Certificate of  
Authority #2019038750

KEY PLAN

Issues		
No.	Description	Date
01	DD Submittal	06/09/20

Revisions		
No.	Description	Date

SWT No. 20827.04  
MSD No. XXMSD-XXXX

Drawn KP, CB Reviewed KDR

Sheet Title  
**ENLARGEMENT PLAN**

Number  
**L-111**

June 5, 2020 - CURRENT PHASE OF PROJECT

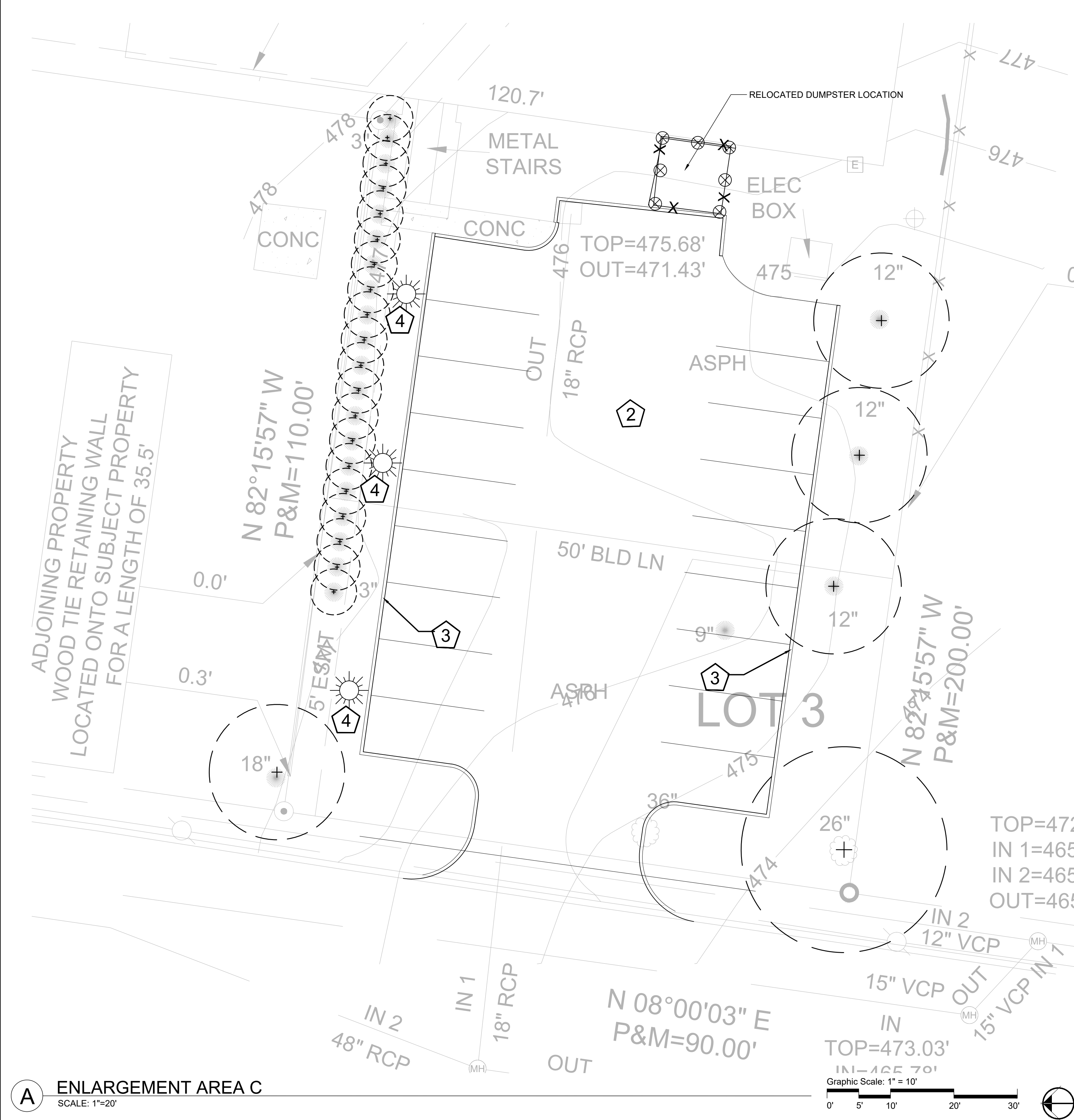

- LEGEND**
- 1 **STANDARD CONCRETE PAVING**  
4" THICK CONCRETE PAVING, BROOM FINISH. EDGES TO BE 1/4" TOOLED RADIUS. SEE CIVIL DRAWINGS FOR LAYOUT. CONTRACTOR TO COORDINATE LOCATION OF ALL JOINTS WITH LANDSCAPE ARCHITECT. SEE DETAIL x/x-x.x.
  - 2 **ASPHALT PAVING**  
FULL DEPTH ASPHALT PAVING FOR VEHICULAR TRAFFIC. SEE DETAIL C/L-500
  - 3 **ROLLED ASPHALT CURB**  
ROLLED ASPHALT PARKING LOT CURB TO MATCH EXISTING WHERE SHOWN. SEE DETAIL X/LX-X
  - 4 **PARKING LOT LIGHT FIXTURE**  
LIGHT FIXTURE TO MATCH EXISTING FIXTURE STYLE, COLOR, HEIGHT, AND LIGHT OUTPUT. FOOTING TO BE INSTALLED PER MANUFACTURER'S RECOMMENDATIONS.
  - 5 **CONCRETE CURB**  
CONCRETE CURB TO MATCH HEIGHT, COLOR AND WIDTH OF EXISTING CONCRETE CURBS. NEW CURBS TO TIE-IN TO EXISTING AS SHOWN.
  - 6 **CONCRETE DRIVE APRON**  
6" DEPTH CONCRETE APRON FOR ROADWAY TRANSITION TO PARKING LOT. SEE DETAIL X/X-X

**A ENLARGEMENT AREA C**  
SCALE: 1"=20'

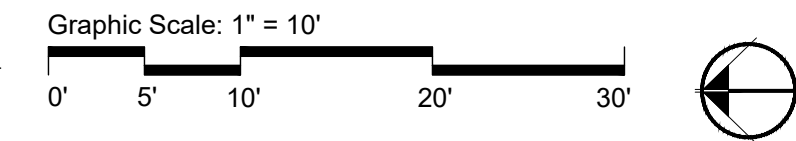

Call Before you DIG  
TOLL FREE  
1-800-344-7483  
MISSOURI ONE-CALL SYSTEM INC.  
MODOT (314) 340-4100

NOTIFY LANDSCAPE ARCHITECT IMMEDIATELY IN EVENTS OF DISCREPANCIES, OMISSIONS, AND/OR CONFLICTS IN THE DRAWINGS OR SPECIFICATIONS. THE CONTRACTOR IS NOT AUTHORIZED TO SCALE THE DRAWINGS. ALL QUESTIONS IN REFERENCE TO CONTRACT DOCUMENTS SHALL BE IMMEDIATELY DIRECTED TO THE LANDSCAPE ARCHITECT.



2515 S. McKnight Road  
St. Louis, MO 63124

Project:  
**McKnight Crossings  
Church of Christ**

Landscape Architect:



7722 Big Bend Blvd.  
St. Louis, MO 63119  
t. 314.644.5700

Consultant Role:  
Consultant Name  
Consultant Address Line 1  
Consultant Address Line 2  
XXX.XXX.XXX

Consultant Role:  
Consultant Name  
Consultant Address Line 1  
Consultant Address Line 2  
XXX.XXX.XXX

Ted Spaid - Landscape Architect  
MO # LA - 162



SWT Design, Inc.  
Missouri State Certificate of  
Authority #2019038750

KEY PLAN

Issues

No.	Description	Date
01	DD Submittal	06/09/20

Revisions

No.	Description	Date
-----	-------------	------

SWT No. 20827.04  
MSD No. XXMSD-XXXXX

Drawn KP, CB Reviewed KDR

Sheet Title  
**SITE PLANTING PLAN**

Number

L-140

PLANT SCHEDULE				
TREES	QTY	BOTANICAL NAME	COMMON NAME	SPACING
AR	4	Acer rubrum	Red Maple	As Shown
CV	12	Chionanthus virginicus	White Fringetree	As Shown
GROUND COVERS	QTY	BOTANICAL NAME	COMMON NAME	TYPE
	2,319 sf	Festuca spp. Fescue Mix	Turf-type Tall Fescue	#1

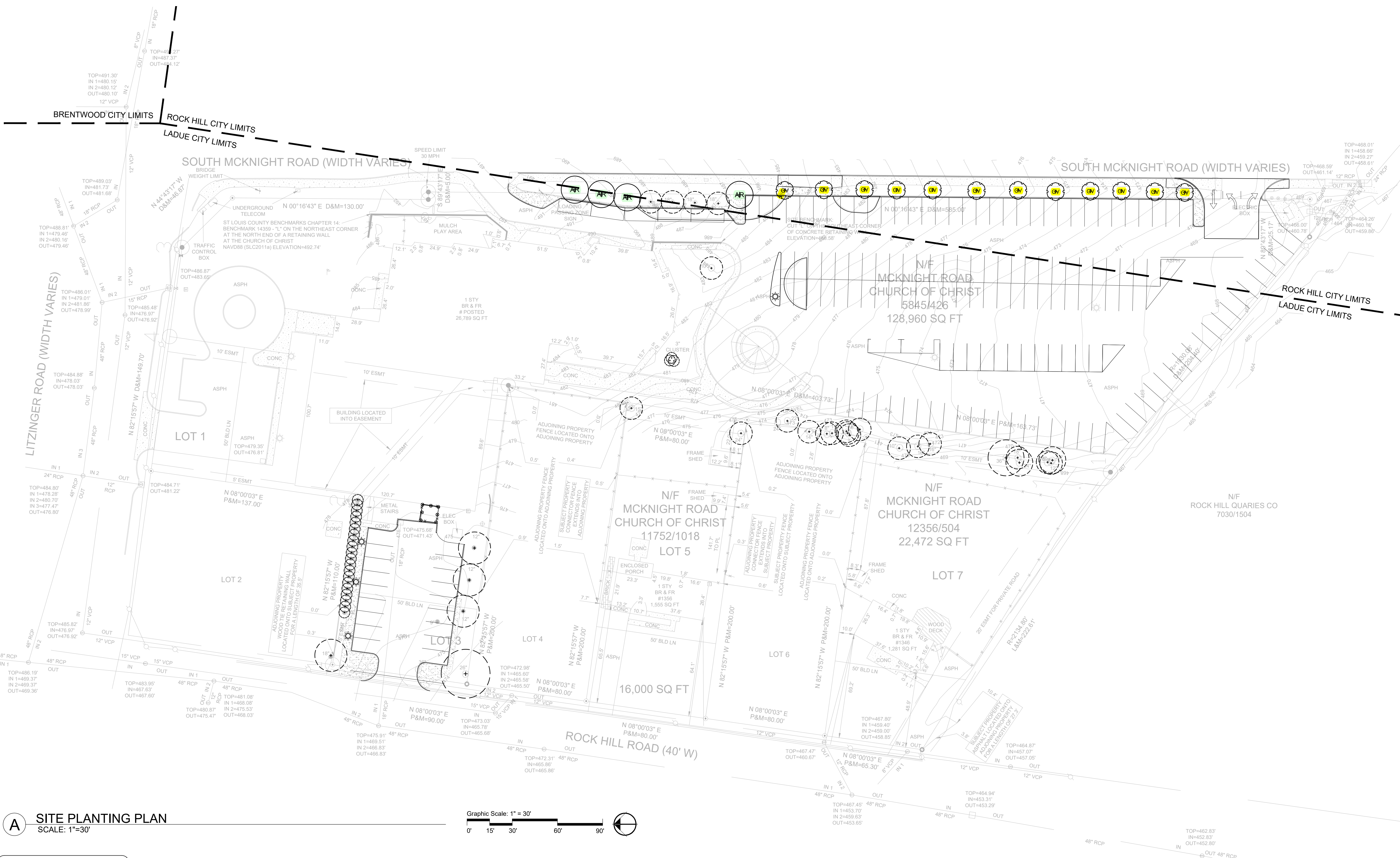

**A SITE PLANTING PLAN**  
SCALE: 1"=30'

Call Before you DIG  
TOLL FREE  
**1-800-344-7483**  
MISSOURI ONE-CALL SYSTEM INC.  
MODOT (314) 340-4100

NOTIFY LANDSCAPE ARCHITECT IMMEDIATELY IN EVENTS OF DISCREPANCIES, OMISSIONS, AND/OR CONFLICTS IN THE DRAWINGS OR SPECIFICATIONS. THE CONTRACTOR IS NOT AUTHORIZED TO SCALE THE DRAWINGS. ALL QUESTIONS IN REFERENCE TO CONTRACT DOCUMENTS SHALL BE IMMEDIATELY DIRECTED TO THE LANDSCAPE ARCHITECT.

June 5, 2020 - CURRENT PHASE OF PROJECT





Issues		
No.	Description	Date
01	DD Submittal	06/05/20

Revisions		
No.	Description	Date

SWT No.	20827.04
MSD No.	XXMSD-XXXXX

Drawn	Reviewed
KP, CB	KDR

Sheet Title  
DETAILS

Number  
**L-500**

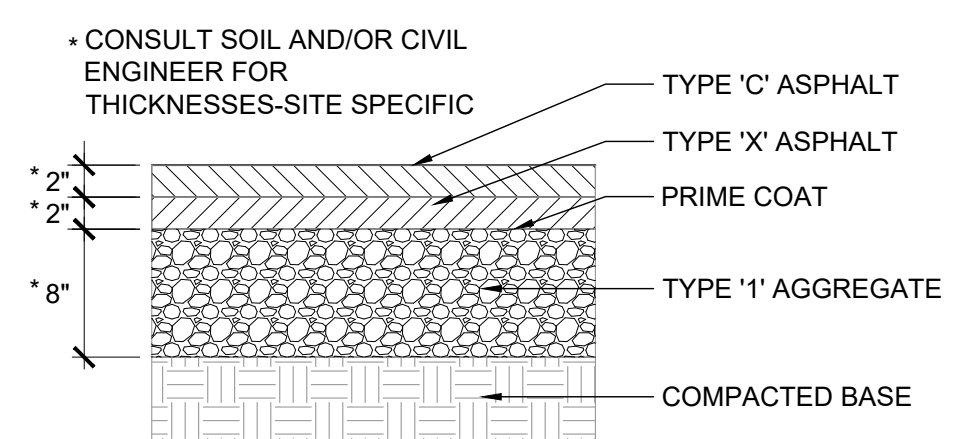

**D ASPHALT ROAD PAVEMENT**  
SCALE: X"=X'

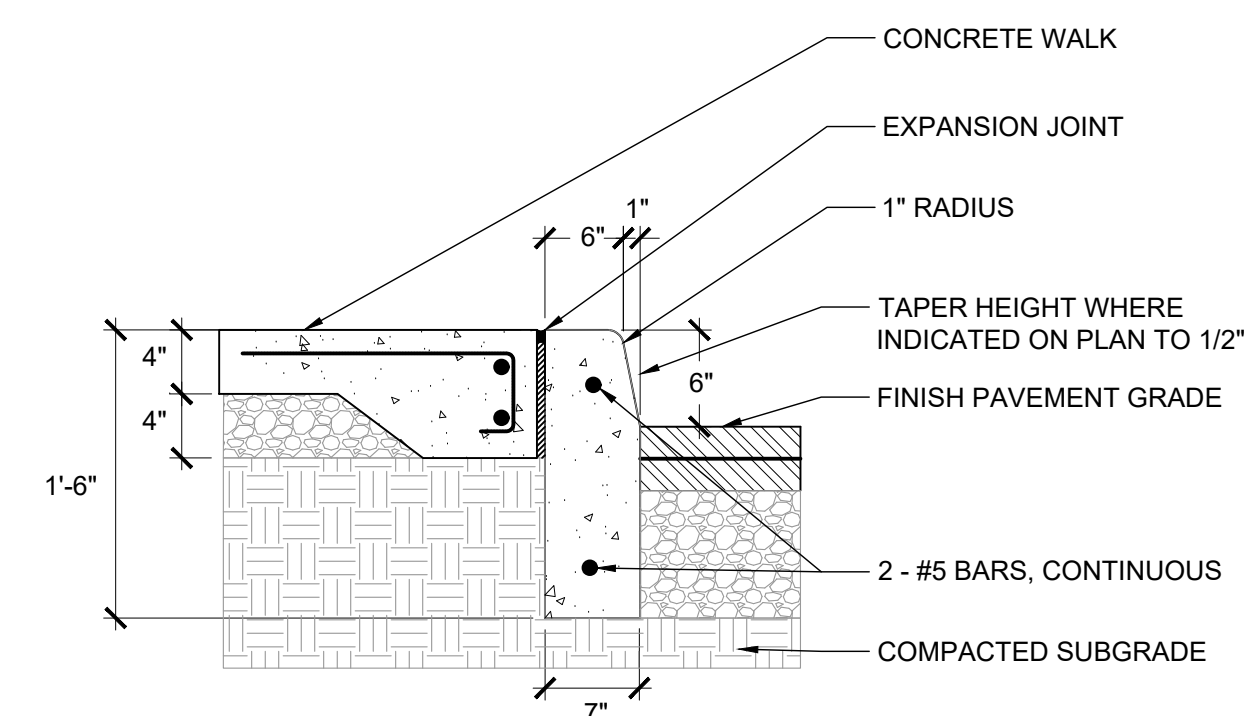

**C CONCRETE CURB AT CONCRETE WALK**  
SCALE: X"=X'

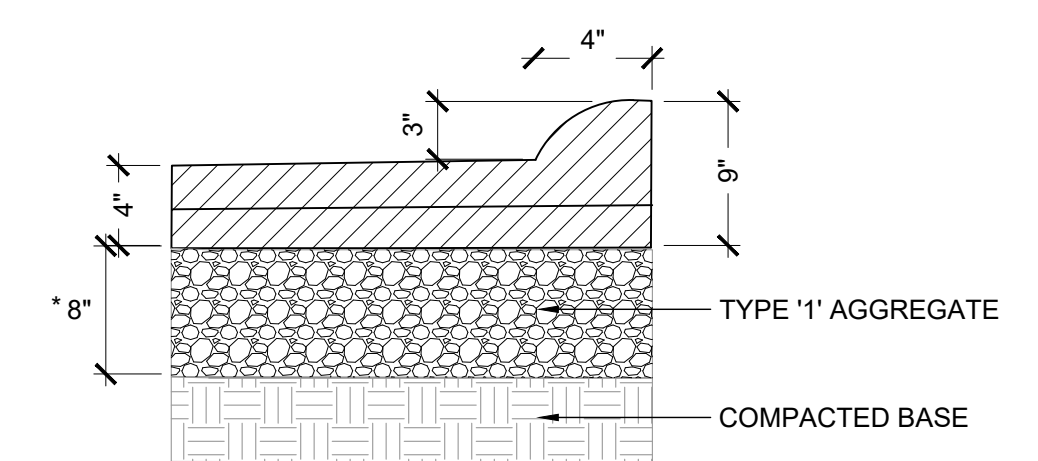

**B ROLLED ASPHALT CURB**  
SCALE: X"=X'

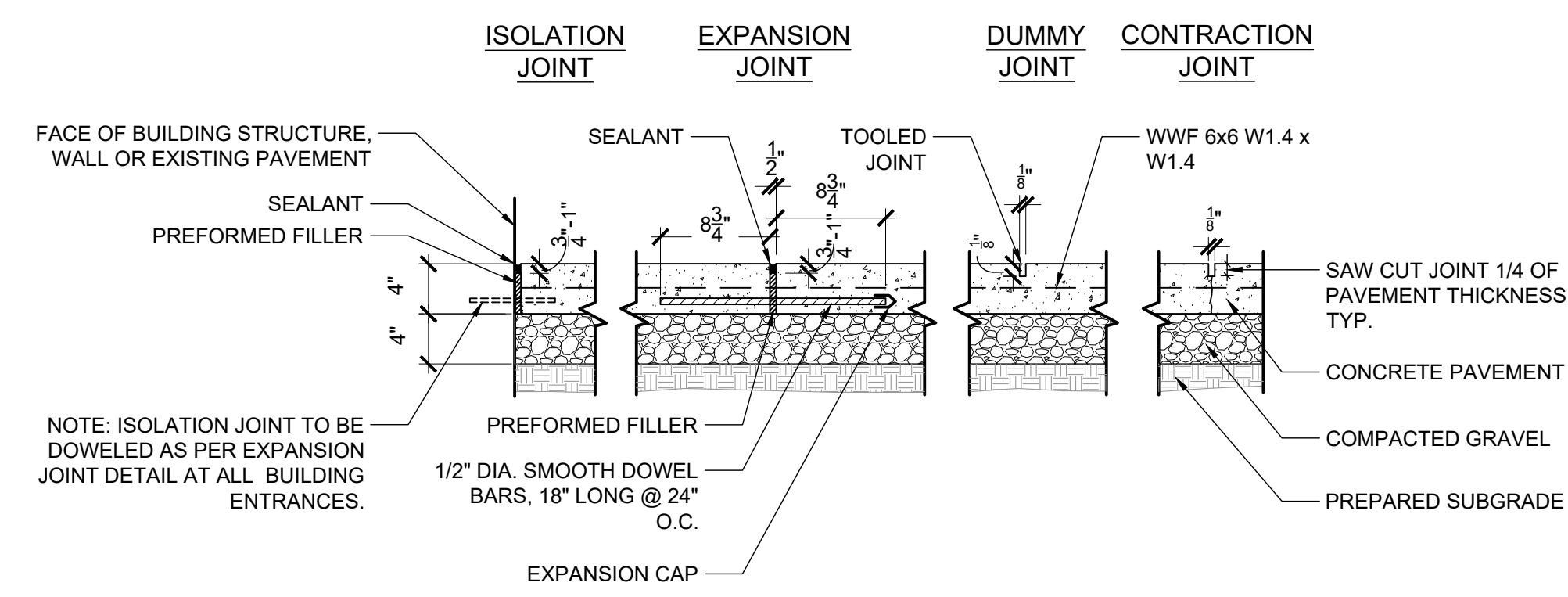

**A 4" THICK CONCRETE PAVING**  
SCALE: X"=X'

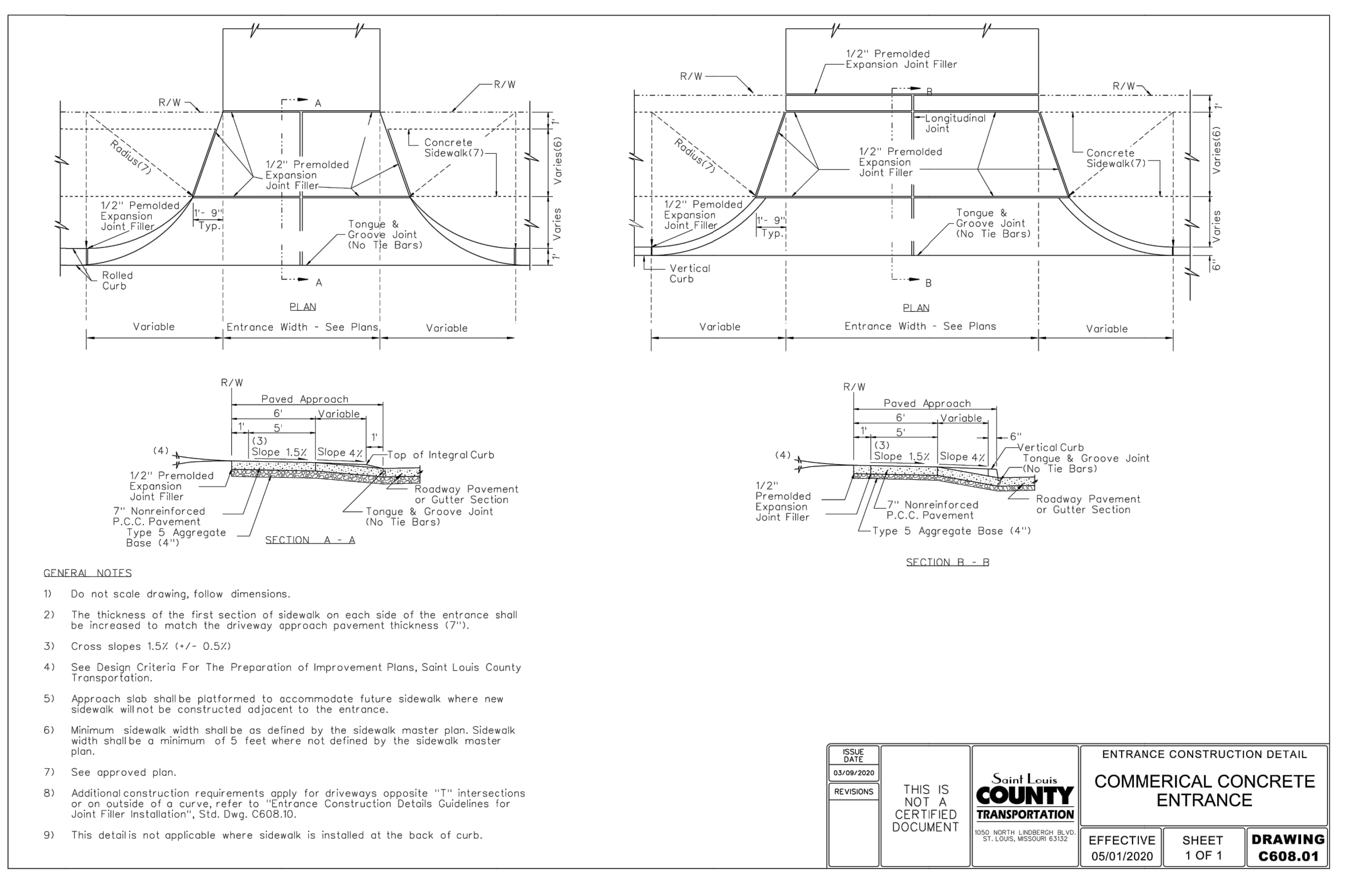

**F CONCRETE ENTRANCE APRON DETAIL**  
SCALE: X"=X'

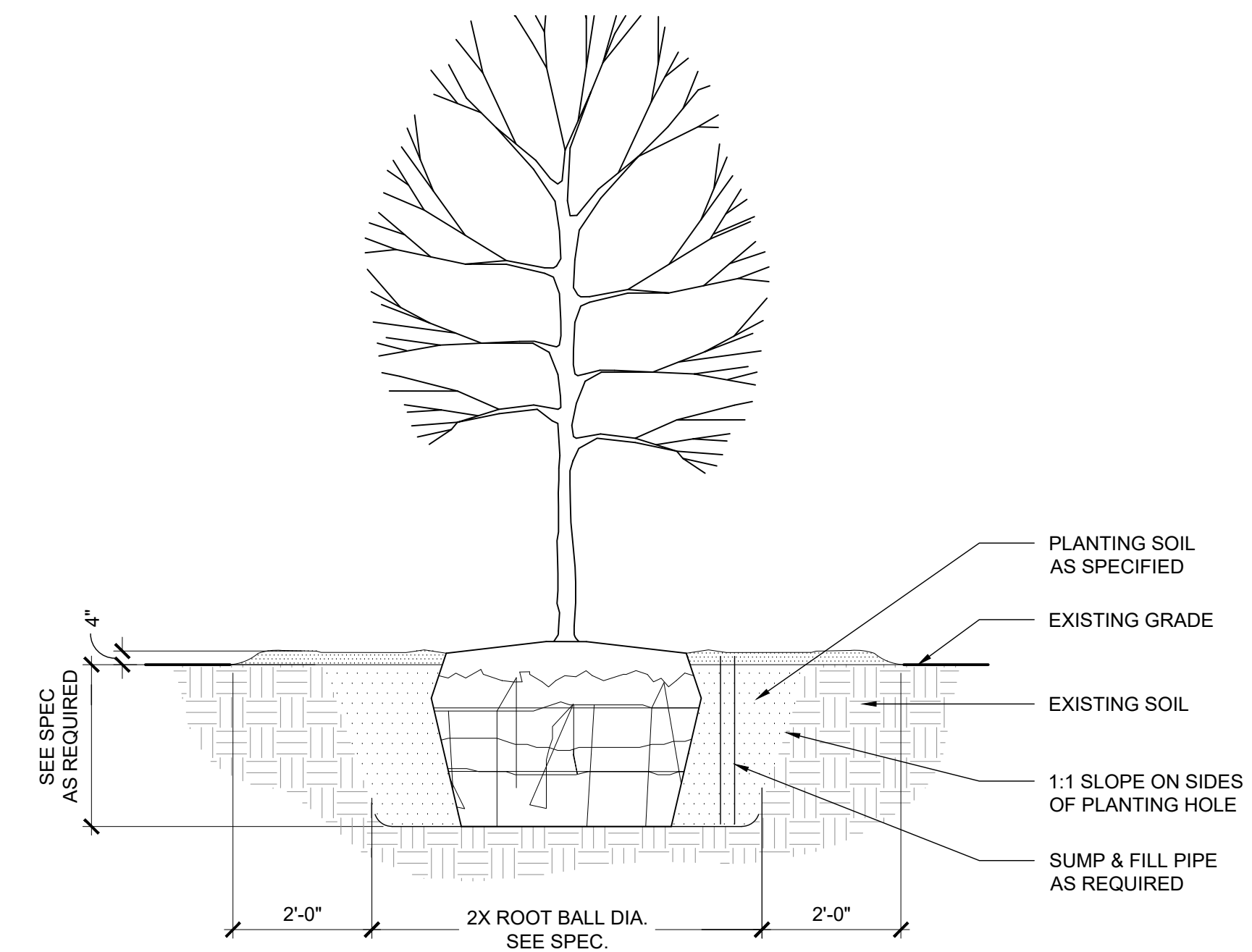

- NOTES:**
- THIS DETAIL APPLIES TO ALL TREE TYPES, CANOPY, FLOWERING, AND EVERGREEN TREES.
  - DO NOT HEAVILY PRUNE THE TREE AT PLANTING. PRUNE ONLY CROSSOVER LIMBS, CO-DOMINANT LEADERS, AND BROKEN OR DEAD BRANCHES. SOME INTERIOR TWIGS AND LATERAL BRANCHES MAY BE PRUNED; HOWEVER, DO NOT REMOVE THE TERMINAL BUDS OF BRANCHES THAT EXTEND TO THE EDGE OF THE CROWN.
  - IF PLANT IS SHIPPED WITH A WIRE BASKET AROUND THE ROOT BALL, CUT THE WIRE BASKET IN FOUR PLACES AND FOLD DOWN 8 IN. INTO PLANTING HOLE.
  - WRAP TREE TRUNKS ONLY UPON THE APPROVAL OF THE LANDSCAPE ARCHITECT. SEE WRAPPING DETAIL.
  - MARK THE NORTH SIDE OF THE TREE IN THE NURSERY, AND ROTATE TREE TO FACE NORTH AT THE SITE WHEN EVER POSSIBLE.
  - SET TOP OF ROOT BALL FLUSH TO GRADE OR 1-2 IN. HIGHER IN SLOWLY DRAINING SOILS.
  - 2 IN. MULCH. DO NOT PLACE MULCH IN CONTACT WITH TREE TRUNK. MULCH RING 6 FT. DIAMETER MINIMUM, 8FT. DIAMETER PREFERRED.
  - STAKE TREES ONLY UPON THE APPROVAL OF THE LANDSCAPE ARCHITECT SEE STAKING DETAIL.
  - PLACE ROOT BALL ON UNEXCAVATED OR TAMPED SOIL.
  - TAMP SOIL AROUND ROOT BALL BASE FIRMLY WITH FOOT PRESSURE SO THAT ROOT BALL DOES NOT SHIFT.
  - EACH TREE MUST BE PLANTED SUCH THAT THE TRUNK FLARE IS VISIBLE AT THE TOP OF THE ROOT BALL. TREES WHERE THE TRUNK FLARE IS NOT VISIBLE SHALL BE REJECTED. DO NOT COVER THE TOP OF THE ROOT BALL WITH SOIL.
  - 4 INCHES (100MM) HIGH EARTH SAUCER BEYOND EDGE OF ROOT BALL.
  - REMOVE ALL TWINE, ROPE AND WIRE, AND BURLAP FROM TOP HALF OF ROOT BALL.

**E TREE PLANTING DETAIL**  
SCALE: X"=X'

PLANT SCHEDULE				
TREES	QTY	BOTANICAL NAME	COMMON NAME	SPACING
AR	4	Acer rubrum	Red Maple	As Shown
CV	12	Chionanthus virginicus	White Fringetree	As Shown
GROUND COVERS	QTY	BOTANICAL NAME	COMMON NAME	TYPE
	2,319 sf	Festuca spp. Fescue Mix	Turf-type Tall Fescue	#1

Call Before you DIG  
TOLL FREE  
**1-800-344-7483**  
MISSOURI ONE-CALL SYSTEM INC.  
MODOT (314) 340-4100